

NEUTRON BEAM INSTRUMENTS AT HARWELL

Edited by

A.H. Baston
and
D.H.C. Harris

Materials Physics Division,
A.E.R.E., HARWELL.

November 1978

HL.78/4137 (C8)
HMD.

CONTENTS

		Page No.
1.	Foreword	4
2.	Reactor Instruments	5
	Single Crystal Diffractometers	
	The Mk VI Diffractometers	8
	Powder Diffractometers	
	CURRAN Powder Diffractometer	11
	10H Powder Diffractometer	14
	PANDA High Resolution Powder Diffractometer	17
	The Guide Tube Small-Angle Diffractometer	20
	Triple Axis Spectrometers	
	Introduction	24
	DIDO Triple-Axis Spectrometer	25
	PLUTO Triple-Axis Spectrometer	29
	Time of Flight Cold Neutron Twin Rotor Spectrometer	33
	Beryllium Filter Spectrometer	36
	MARX Spectrometer	39
	The Harwell Small-Angle Scattering Spectrometer	43
3.	LINAC Instruments	45
	Total Scattering Spectrometer Mk.II (T.S.S.)	47
	The Back Scattering Spectrometer (BSS)	51
	Active Sample Diffractometer	54
	Inelastic Rotor Spectrometer (IRS)	57
	The Constant Q Spectrometer (CQS)	60
	Future Instruments on LINAC	63
4.	Ancillary Equipment	64
	Cryostats	64
	Superconducting Magnets	65
	Electromagnets	65
	Furnaces	65

ILLUSTRATIONS

FIGURE		Page No.
1	DIDO instruments	6
2	PLUTO instruments	7
3	Schematic layout of Mark six diffractometers	10
4	Schematic layout of CURRAN diffractometer	13
5	Schematic layout of 10H powder diffractometer	16
6	Schematic layout of PANDA diffractometer	19
7	Schematic layout of guide tube small angle diffractometer	23
8	Schematic drawing of DIDO triple axis (10H facility)	28
9	Schematic layout of PLUTO triple axis spectrometer	32
10	Cold neutron spectrometer expt 4H-5 DIDO	35
11	Schematic layout of DIDO beryllium filter spectrometer	38
12	Schematic diagram of PLUTO MARX spectrometer	42
13	Schematic layout of small angle scattering spectrometer plan view	44
14	Schematic layout of Harwell LINAC condensed matter cell	46
15	Schematic layout of LINAC total scattering spectrometer Mk II	50
16	Resolution of backscattering spectrometer	52
17	Schematic layout of backscattering spectrometer	53
18	Active sample diffractometer	56
19	Schematic layout of inelastic rotor spectrometer	59
20	The allowed regions of (Q, ω) space for graphite spacings	62
21	Typical scattering triangles iron (100) plane: $q_{110} = 0.5 \text{ \AA}^{-1}$	62
22	Spectrometer layout the constant Q spectrometer	62

1. FOREWORD

An agreement exists between the Science Research Council and A.E.R.E. (Harwell) for the joint provision of neutron beam facilities for U.K. scientists at Harwell and in academic institutions. This booklet gives information about these facilities. The main characteristics of each beam instrument are given but, because of continuing development of techniques and of possible special requirements, a potential user should seek the latest information about instruments from the editors A.H. Baston and D.H.C. Harris or about a particular instrument as follows:—

Dr. M.T. Hutchings	PLUTO and DIDO Triple Axis and MARX Spectrometers
Dr. D.I. Page	CURRAN, 10H Powder Diffractometer, and Small Angle Scattering Spectrometer
Dr. M.W. Thomas	PANDA and Beryllium Filter Spectrometer Active Sample Diffractometer (LINAC)
Mr. K.D. Rouse	The Mk VI Diffractometers
Dr. D. Worcester, Queen Elizabeth College, London	Guide Tube Diffractometer for Small Angle Diffraction
Dr. C.J. Wright	Time of Flight Spectrometer
Dr. R.N. Sinclair	Total Scattering Spectrometer (LINAC)
Dr. C.G. Windsor	Back Scattering Spectrometer (LINAC) Constant Q Spectrometer (LINAC)
Mr. B. Boland, Rutherford Laboratory	Inelastic Rotor Spectrometer (LINAC)
Mr. D.H.C. Harris	Ancillary Equipment

The following definitions apply to terms used in the notes on the instruments:—

Neutron momentum $\hbar\mathbf{k}$ is related to wavelength and energy by the following:

$$k = \frac{2\pi}{\lambda} \quad E = \frac{\hbar^2 k^2}{2m}$$

where λ is the wavelength and m is the neutron mass, \mathbf{k}_i and \mathbf{k}_f are the incident and scattered wave vectors. The scattering vector $\mathbf{Q} = \mathbf{k}_i - \mathbf{k}_f$ and the neutron energy loss is $\hbar\omega = h\nu = E_i - E_f$ where E_i and E_f are the incident and scattered neutron energies.

2. REACTOR INSTRUMENTS

The instruments described in this section, are situated at the end of beam holes in the Harwell reactors DIDO and PLUTO. The reactors are heavy-water moderated and cooled, graphite-reflected, and helium blanketed with secondary cooling by light water and cooling towers. They normally operate at 25.5 MW for 24 days and are then shut down for 4 days to change fuel and experimental equipment. The shutdown dates of the two reactors are staggered by two weeks. The fuel consists of tubes containing enriched uranium/aluminium alloy clad by aluminium.

The positions of the holes used by the instruments described are shown in the figures overleaf in plan view. On PLUTO the holes are tubes passing horizontally through the D₂O reflector tank near and tangential to the core. The thermal neutron flux from the holes is approximately 1×10^{14} neutrons cm⁻² s⁻¹. On DIDO the holes are horizontal re-entrant radial tubes in the D₂O reflector tank. 4H holes give a thermal neutron flux of from 0.7 to 1.5×10^{14} neutrons cm⁻² s⁻¹ and the 10H hole about 1×10^{14} neutrons cm⁻² s⁻¹.

DIDO

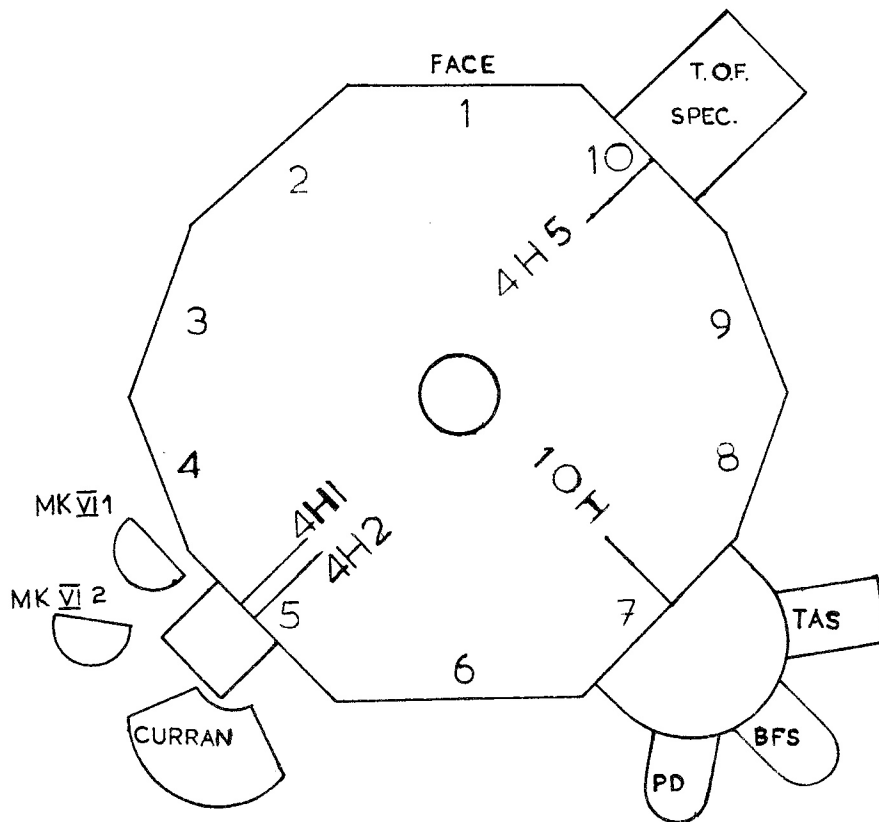

AERE - R 9278 Fig. 1

DIDO instruments

4H1	Mk.VI 1	4 circle diffractometer
	Mk.VI 2	2 circle diffractometer
4H2	CURRAN	CURRAN powder diffractometer
4H5	TOF SPEC	Time of flight spectrometer
10H	PD	2 axis powder diffractometer
	BFS	Beryllium filter spectrometer
	TAS	Triple axis spectrometer

PLUTO

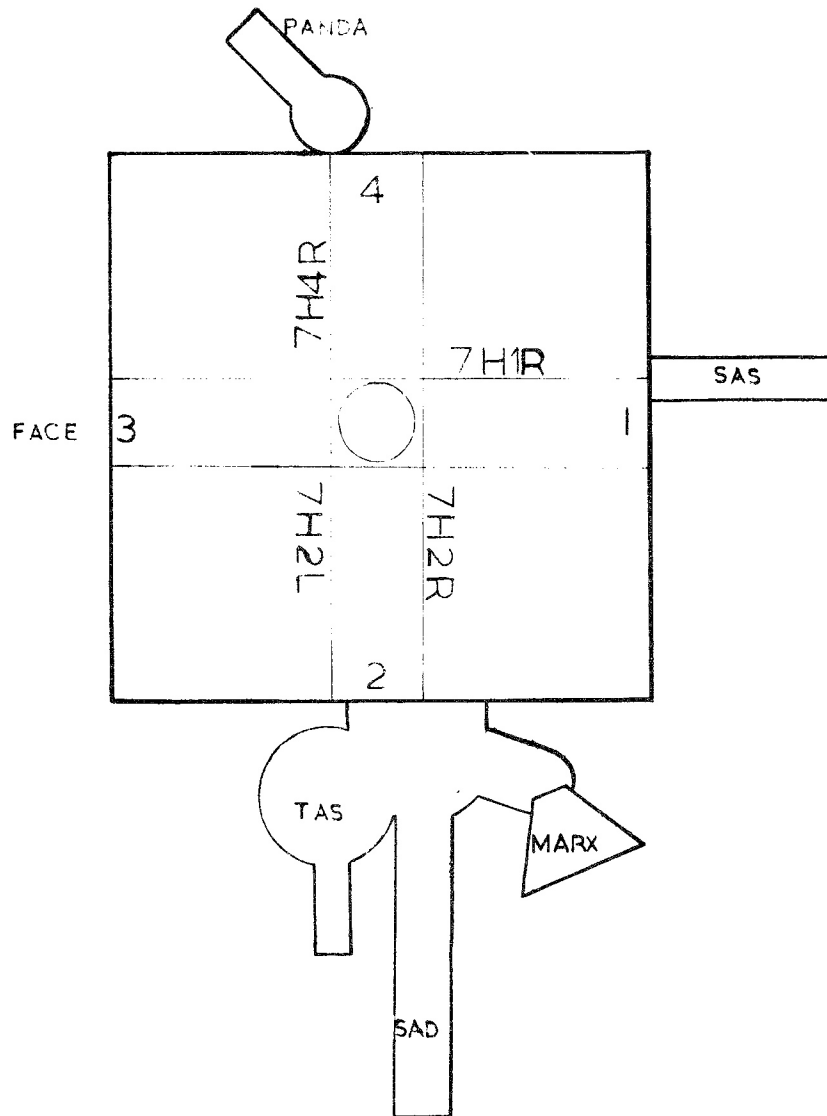

AERE - R 9278 Fig. 2
PLUTO instruments

7H1R	SAS	Small angle scattering instrument
7H2R	MARX	MARX spectrometer
	SAD	Guide tube diffractometer for small angle diffraction
7H2L	TAS	Triple axis spectrometer
7H4R	PANDA	PANDA powder diffractometer

The Mk VI Diffractometers

These two instruments are designed primarily for single crystal studies and have been robustly constructed to accept a wide range of attachments such as furnaces, cryostats and electromagnets. The basic instrument comprises an $\Omega/2\theta$ assembly to which additional equipment is added as required. Control of the diffractometers is either manual or by a PDP-8E computer using the ANDROMACHE control system which is designed to control simultaneously two 4-circle neutron diffractometers and provide data reduction and graphical display facilities at remote television and teletype terminals.

Channel 1

A two-circle attachment with ϕ and χ movements has been added to the basic unit thus converting it to a conventional four-circle diffractometer. A furnace capable of 800°C and a cryostat operating in the range 10 K to 300 K can be mounted about the ϕ -axis allowing the collection of three-dimensional data at both high or low temperatures. At present, a fixed-wavelength of 1.183 Å at the sample is obtained by reflection from the (331) planes of a Cu monochromator.

This diffractometer is used primarily for structure determinations of single-crystal materials and studies of phase-transition phenomena with particular emphasis on hydrogen-bonding problems.

Channel 2

An alternative carrier for the neutron detector shield has been added to the basic unit which permits the detector to be elevated 35° and depressed -10° from the horizontal plane, thus allowing partial three-dimensional data to be collected when using furnaces or cryostats and minimise the number of sample reorientations needed. The ω shaft will accommodate a two-circle attachment, cryostats with arcs, furnaces and electromagnets up to a loading of 200 kg. The lower take-off angle of 45° implies that data collected at large 2θ values ($\sim 120^\circ$) have poorer resolution or smaller slits are available for the detector to help overcome this difficulty. The wavelength range available is 0.835 Å to 1.308 Å in discrete steps.

This instrument is used principally for studies of magnetic effects in single-crystal materials at high or low temperatures but recently it has been extensively used for structural studies at short wavelengths.

Mk VI Diffractometers Instrument Details

Beam Hole	4H1, DIDO
Maximum Flux at Specimen	$7 \times 10^5 \text{ n cm}^{-2} \text{ s}^{-1}$
Beam Size at Specimen	$1.2 \times 0.9 \text{ cm}^2$
Background	40 cpm
Specimen Size commonly 2 or 3 mm cubes	

No. 1 Instrument

Incident Wavelength	1.181 Å
Take-off Angle from Monochromator	90°
Scattering Angles	(2θ) -4° to +110° (χ) +215° to -190° (ϕ) -187° to +187° (Ω) +231° to -205°

Cryostat for temperatures down to 10°K

No. 2 Instrument

Incident Wavelength	0.835, 0.886, 0.996, 1.085 and 1.308 Å
Take-off Angle from Monochromator	45°
Scattering Angles	(2θ) -20° to 133° (Ω) +200° to -217°

The vertical circle on No. 2 instrument has been removed and replaced by a cryostat for use down to 4.2°K. A lifting detector assembly has been fitted which is hand set and can be depressed by -10° and elevated to +35° from the horizontal plane.

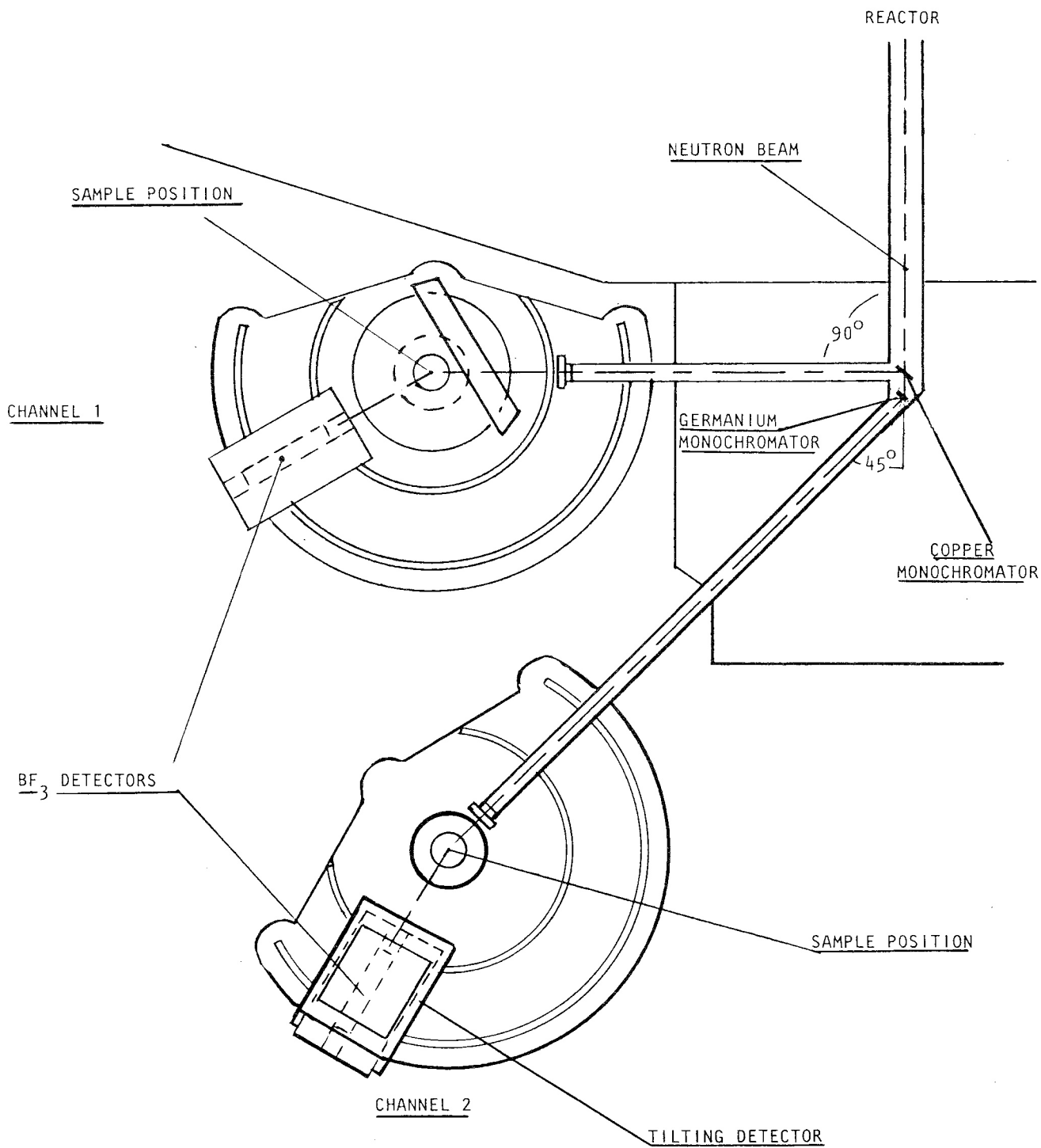

AERE - R.9278 Fig. 3
 Schematic layout of mark six diffractometers

CURRAN Powder Diffractometer

This diffractometer is suitable for structural studies of powders, liquids and amorphous materials in the range of momentum transfer $Q = 0.2$ to 11.4 \AA^{-1} .

The angular resolution is good ($\sim 0.5^\circ$) at low values of 2θ but increases rapidly for $2\theta > 50^\circ$.

The background is reasonably low so the instrument is of particular value for low intensity scattering samples and experiments where it is wished to take differences between successive spectra (e.g. variable pressure and temperature runs).

There is independent 2θ and ω -movement to facilitate the use of flat or cylindrical samples and the whole range of Harwell's cryostats, furnaces and magnets can be accommodated. There is an extract duct for potentially noxious samples.

The instrument is fully automated in operation and data acquisition is by punched tape and teletype.

CURRAN Instrument Details

Monochromator	Ge
Take-off Angle	47.5°
Wavelength	0.90, 1.08, 1.37, 2.63 Å
Maximum Beam Size	42 × 34 mm ²
Usual Sample Size	10 mm ϕ × 40 mm
Flux at Sample	2 × 10 ⁶ ncm ⁻² s ⁻¹ (Max)
Resolution	0.55° at 15° 0.45° at 30° 0.85° at 60° 1.55° at 80°
Angular Range	-10° to 110°
Minimum Useful Angle	~ 5°
Minimum Step Length	0.01°
Background (No Specimen)	10 cpm (2 θ =40° to 100°) 20 cpm (2 θ =5° to 40°)
Detector System	5 × 50 mm ϕ BF ₃ , 10° apart Ceramic End Window
Q-Range (Å ⁻¹)	0.6 to 11.4 (0.9 Å) 0.2 to 4.8 (2.63 Å)

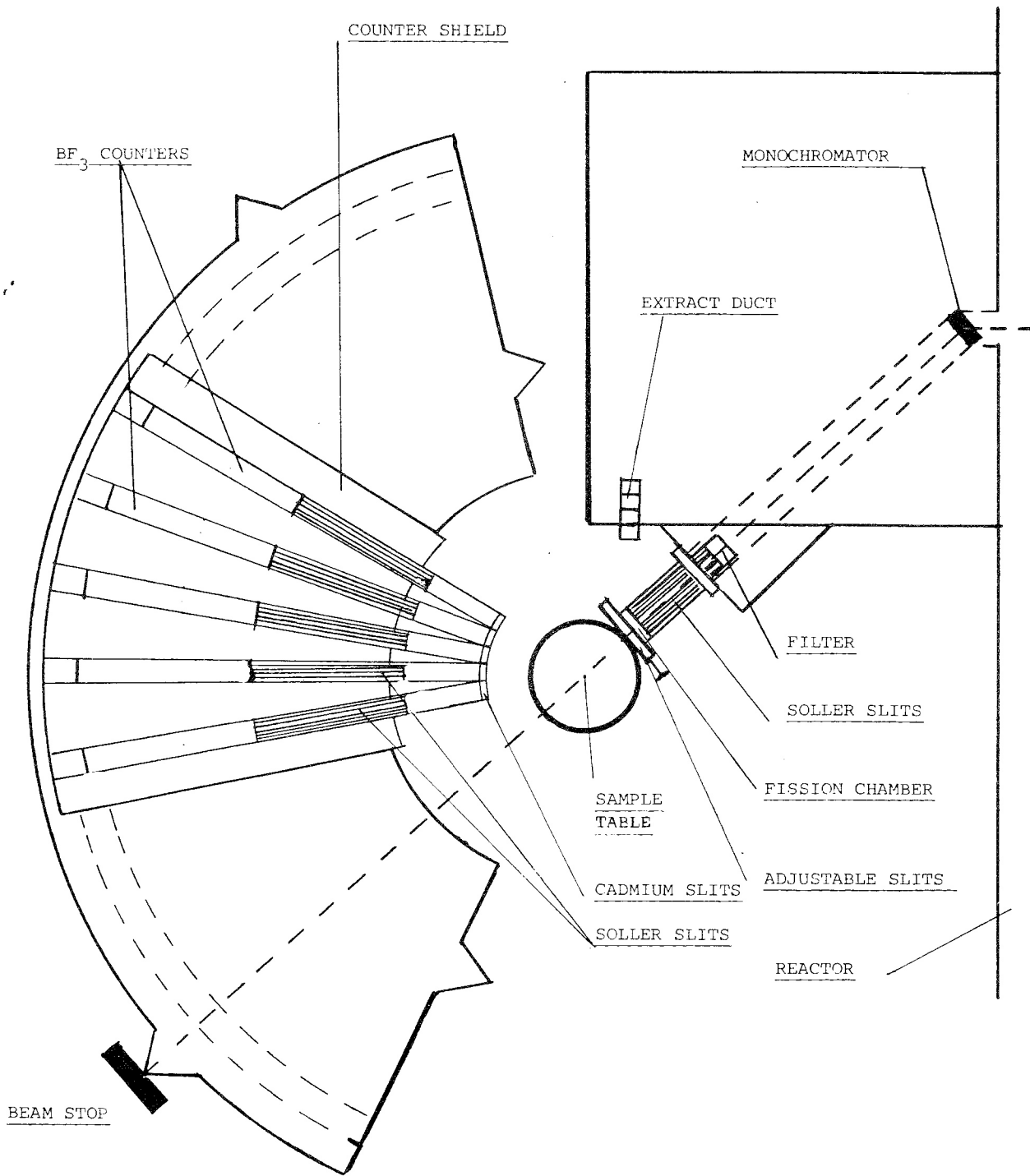

AERE - R.9278 Fig. 4
 Schematic layout of CURRAN diffractometer

10H Powder Diffractometer

This diffractometer has good angular resolution ($\sim 0.5^\circ$) for all values of 2θ and so is particularly suitable for structure studies of powders. It can also be used for structure work on liquids and amorphous solids over the range of momentum transfer $Q = 0.8$ to 11.4 \AA^{-1} .

The machine background is high due to the close proximity of other spectrometers and a sample giving medium or high intensity scattering is advised.

There is independent 2θ and ω movement to facilitate the use of flat or cylindrical samples and the whole range of Harwell's cryostats, furnaces and magnets can be accommodated.

The instrument is fully automated in operation and data acquisition is by punched tape and teletype.

10 HPD Instrument Details

Monochromator	Cu (4,2,2)
Take-off Angle	85°
Wavelength	1.00 Å
Maximum Beam Size	45 × 33 mm ²
Usual Sample Size	10 mm ϕ × 40 mm
Flux at Sample	2 × 10 ⁶ ncm ⁻² s ⁻¹
Resolution	0.6° at 2 θ = 25° 0.45° at 2 θ = 55° 0.55° at 2 θ = 85° 0.7° at 2 θ = 110°
Angular Range	-20° to 130°
Minimum Useful Angle	8° (1)
Minimum Step Length	0.01°
Background (No Specimen)	50 cpm (2 θ = 55° to 130°) 65 cpm (2 θ = 35°) 100 cpm (2 θ = 25°)
Detector System	3 × 50 mm He ³ , 14° apart or 5 × 50 mm He ³ , 7° apart (2)
Q-Range (Å ⁻¹)	0.8 to 11.4 Å ⁻¹ (1.0 Å)

- (1) A new nose-piece for the counter shield is being manufactured (mid-1978) which should reduce this angle appreciably.
- (2) Using the 5 detector array increases the background by ~30%.

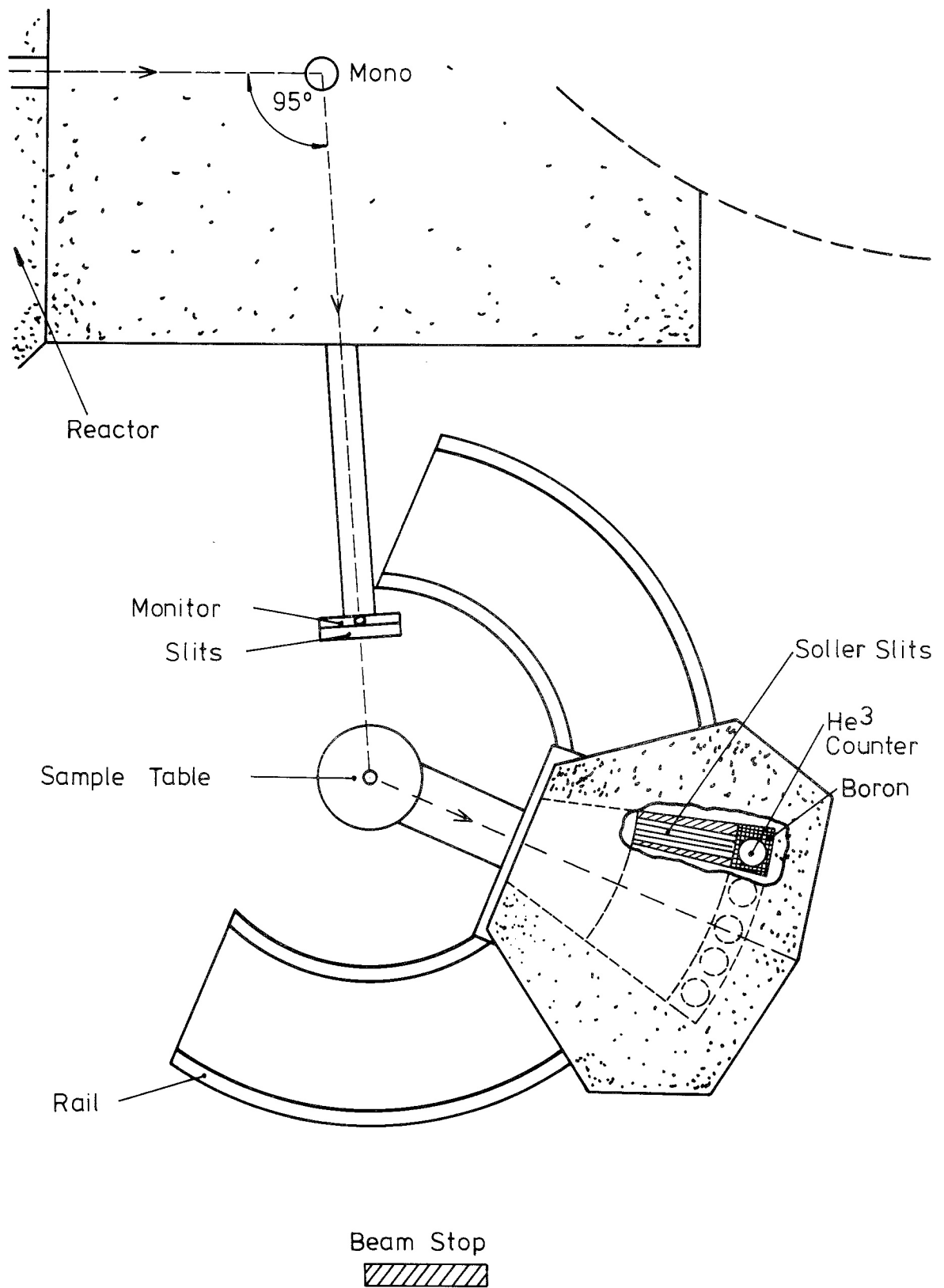

AERE - R.9278 Fig.5
 Schematic layout of 10H powder diffractometer

PANDA High Resolution Powder Diffractometer

This instrument is designed as a general purpose powder diffractometer. Its prime use is for powder profile refinement of structures over a wide range of temperatures. Because it has a variable take-off angle (TOA) the instrument can be used either in a high intensity mode with a low TOA or in a high resolution mode with a high TOA. Because of the demand for profile analysis it is generally used at the present in the latter mode.

Special features include:

1. Variable take-off angle ($9-90^\circ$) giving good resolution up to 100° . The focussing angle can be changed to give the experimenter optimum resolution over a wide range of Q space.
2. Choice of squashed germanium, perfect germanium or copper monochromators. These combined with the variable TOA feature allow the user a very wide choice of wavelengths in the range $.7 \text{ \AA}$ to 4 \AA . These can be easily selected by either rotating the monochromator or changing the TOA.
3. An array of BF_3 detectors arranged on a 3×3 matrix. This allows the user to change the effective vertical collimation and hence improve counting statistics.

The instrument has been used for numerous investigations over the past ten years. Studies of phase changes have ranged from 10 K to 1900 K. Materials studied have included polymers such as polypropylene, PTFE and polyethylene; organics such as adamantane, acetic acid and chlorinated aromatics, complex inorganics such as zeolites and β -alumina, simple ceramics such as UO_2 and ThO_2 as well as metallic compounds and alloys. Defect structures and doped fluorite structures have also been extensively investigated. Recently, absorbed gases on surfaces have been examined. The instrument can be usefully used for any investigation involving Bragg diffraction. At Harwell, however, it is usually used where high resolution is required, at the expense of intensity.

Physical Description

The instrument is shown in plan view in the accompanying drawing. The TOA is changed by rotating the shielding turret together with the specimen arm. Three slots are available to vary $2\theta_m$ from 0° to 90° . The monochromator is shown in reflection. Normally the Copper monochromator is used in this sense whereas the germanium monochromator is used in transmission (rotated by 90°). Planes are selected by a rotation about an axis in the plane of the drawing. The angle θ_m is matched to suit $2\theta_m$ by rotating the monochromator plug (ω rotation). The sample table can be rotated continuously, or in steps either with or without 2θ . The printout of the nine BF_3 counters can be adjusted by a diode board. Various scans can be selected ($\omega-2\theta$, ω , or 2θ) by a hard wired unit using thumb wheel switches. This unit can also be used to set monitor count limits. Data output is via a teletype with a paper tape punch.

PANDA Instrument Details

Beam hole	7H4R PLUTO
Monochromators	Germanium, squashed germanium and copper.
Wave length range	.7 Å to 4.6 Å
Flux	$3 \times 10^5 \text{ n cm}^{-2} \text{ s}^{-1}$
Resolution	.3° angular $\Delta d/d \sim 3 \times 10^{-3}$ ($2\theta_M = 90^\circ$)
Angular range	$-60^\circ < 2\theta < 110^\circ$ (depends on TOA) $0^\circ < \omega < 360^\circ$
Beam size at sample	65 × 65 mm
Collimation	α_1 20' (fixed) α_2 variable (slits and sollers) α_3 13.4' and 30'
Detectors	9 × BF ₃ at 70 cm Hg (5 cm diameter)
Background without sample	10 cpm
Filters	Pyrolytic graphite and beryllium
Ancillary equipment	Cryostats 1.5 K to 300 K. Various types, e.g. centre loading variable temperatures. Furnace (1600°C)

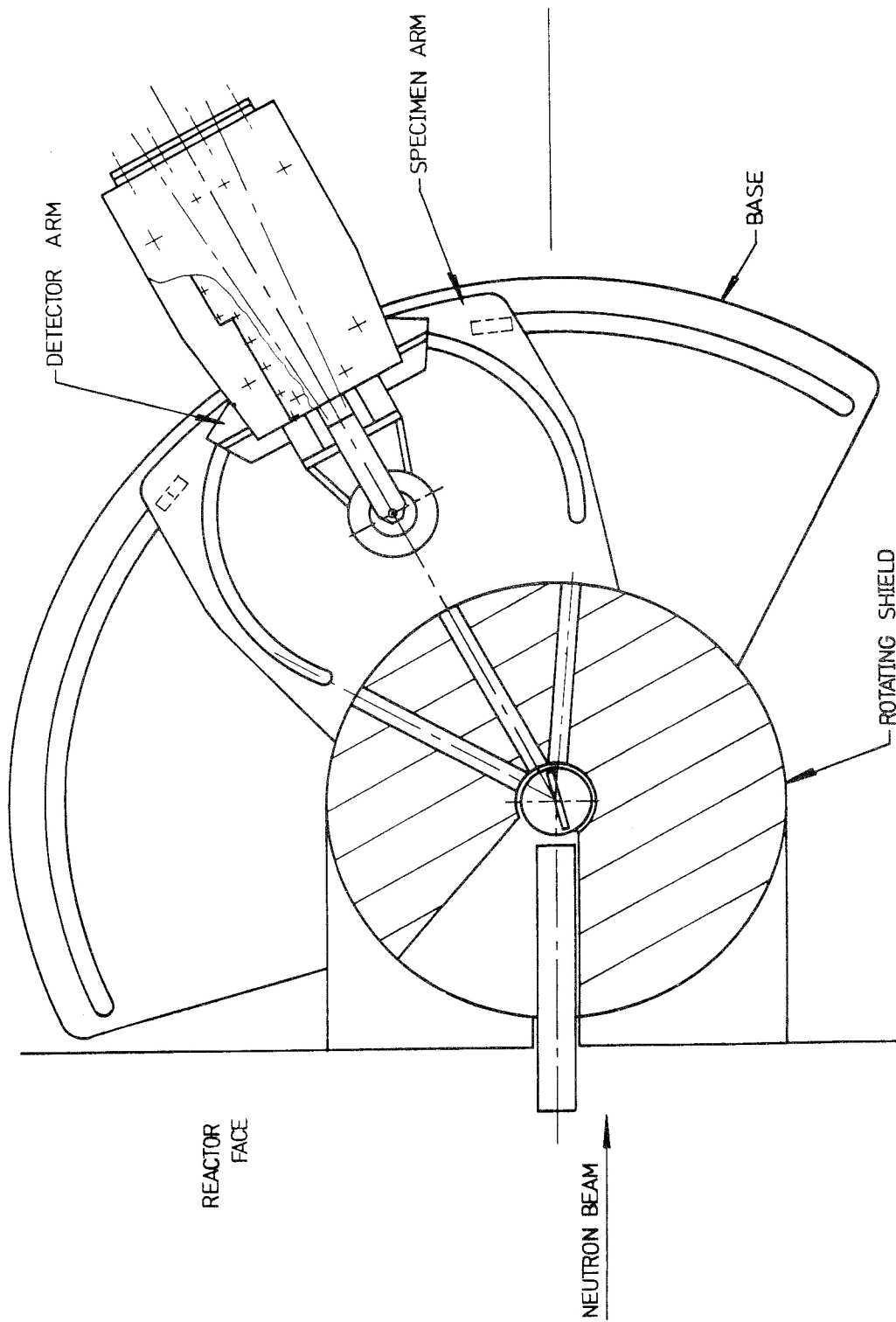

AERE - R.9278 Fig. 6
Schematic layout of PANDA diffractometer

The Guide Tube Small-Angle Diffractometer

The PLUTO small-angle diffractometer (S.A.D.) has been used for measurements of neutron diffraction and neutron small-angle scattering from crystal structures with large unit cells and for macromolecular systems, ranging in size from 10-20 Å. Biological materials have been extensively studied; in solution, as fibres, and in lamellar arrays. Other utilizations have included studies of polymers, liquid crystals and clays.

In solution scattering work, the instrument is suitable for measuring radii of gyration up to about 50 Å. In addition, the scattering profile at higher angles than the Guinier region can be measured, but data are usually limited to a decrease of intensity by a factor of 200-330 from the intensity of the central maximum. For biological materials, the best measurements are made with D₂O buffer as solvent, because of the high contrast and the lower incoherent scattering background for D₂O than for H₂O.

The instrument is particularly well-suited for diffraction studies of lamellar materials. A very large amount of work has been done with biological smectic liquid crystals made from components of biological membranes. Deuterium labelling and deuterium exchange in such structures provide direct methods of structural analysis. Lamellar materials with Bragg spacings up to 200 Å have been measured.

The instrument consists of a copper guide tube which is filled with helium and provides a vertical and horizontal collimated beam at the diffractometer. Near the reactor face, the neutron beam is filtered by Beryllium polycrystals to remove neutrons with wavelengths less than 4 Å, and by a single crystal of Bismuth which attenuates gamma radiations. Only neutrons with wavelengths longer than 4 Å enter the guide tube and are incident upon the specimen at the diffractometer. A fission chamber at the end of the guide tube monitors the incident beam.

Details of the diffractometer are shown in the figure overleaf. Soller collimators can be used before and after the specimen depending on the collimation required. Several collimators are available, which provide the same divergence as the guide tube, or additional collimation down to about 0.15°. A graphite crystal after the specimen reflects neutrons of wavelengths about 4.7 Å into the BF₃ counter. This geometry has the advantage of keeping a fixed $\Delta\lambda/\lambda$ regardless of the collimation. With no additional collimators, the flux at the specimen position is about $6 \times 10^4 \text{ cm}^{-2} \text{ s}^{-1}$.

The diffractometer is controlled by an electronics unit directly below the diffractometer platform. Both the specimen table and the diffractometer arm can be automatically set at angles specified to 0.01° by stepping motors and digitizer readouts. The electronic control unit contains a hard-wired memory which will accept a series of scan commands, and execute them in sequence. Three types of scans are available: omega scans (detector fixed, specimen rotating), two-theta scans (specimen fixed, detector rotating) and omega-two-theta scans (both specimen and detector rotating with steps in the ratio 1/2). For a prescribed monitor count, the specimen and detector angles, the time of the count, and

the BF_3 counts collected are recorded on a teletype and may also be punched on 8-hole paper tape.

For further information see:

B.C.G. Haywood and D.L. Worcester, J. Phys. C 6, 569 - 571 (1973).

Guide Tube SAD Instrument Details

Diffracted wavelength (usual)	4.7 Å
Max. flux at the specimen	$6 \times 10^4 \text{ n cm}^{-2} \text{ s}^{-1}$
Beam size	6 cm \times 3 cm
Resolution	$\Delta Q \geq 1.5 \times 10^{-2}$
Range of scattering angle	-40 to 100°
Background	No sample, $\sim 5/\text{min}$.

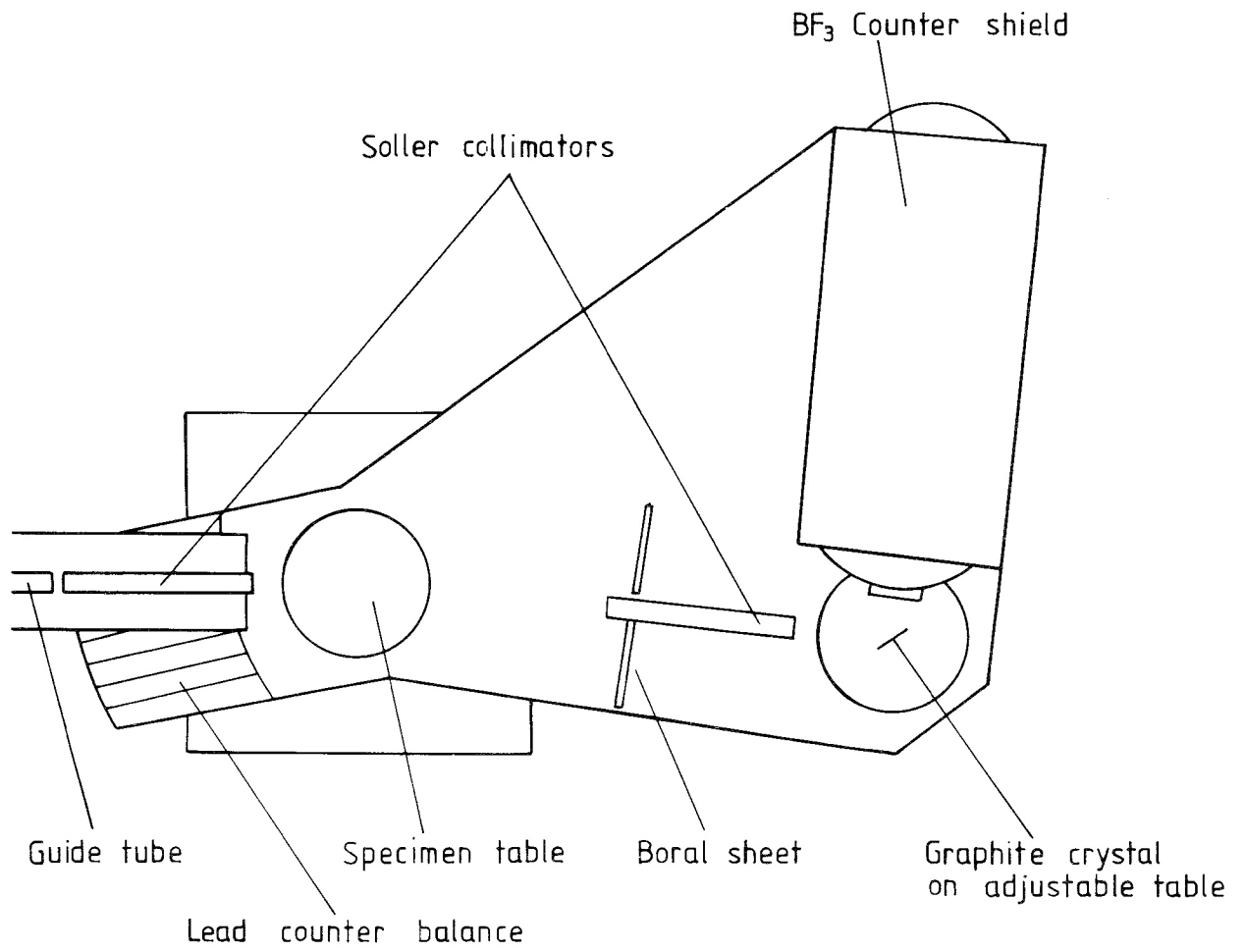

AERE - R.9278 Fig. 7
 Schematic layout of guide tube small angle diffractometer

Triple Axis Spectrometers

Introduction

The two instruments are conventional medium energy range spectrometers with principal use in the measurement of $S(Q,\omega)$ at constant Q or constant $\hbar\omega$, giving for example the energy dispersion relation of excitations in solids: phonons, magnons, excitons, the form of critical scattering etc. Software programs in the controlling computers are very versatile and enable all relevant parameters to be changed automatically.

The instruments may be used as two-axis spectrometers with the advantage that automatic scans may be made in any direction in the reciprocal space of a single crystal sample. They may also be used as powder or single crystal diffractometers with elastic energy selection by the analyser.

DIDO Triple-Axis Spectrometer

Uses

Monochromator and analyser crystals can be readily changed, as can the soller slit collimation. Scans of (Q, ω) can be made by varying Q , or $\hbar\omega$ via E_f . At present only one take-off angle from the monochromator is available ($2\theta_M = 40.5^\circ$), but in the near future θ_M and $2\theta_M$ will be automatically variable via the software programs, with $2\theta_M$ varying between 30° and 70° , so that $\hbar\omega$ scans may be also made by varying E_i .

Description

The instrument shares its monochromator-drum shielding with the two other instruments of the 10H complex:— the Beryllium Filter spectrometer and the Powder Diffractometer. The main scattering arm from the sample is cantilevered from a rotating gun mounting, and the analyser axis and detector shield are in turn cantilevered from the arm. The sample table moves relative to the main arm on which it is mounted. A system of Jabroc shielding houses the S-A soller and contains curved boral plates which rotate around the analyser, Jabroc wedges shield the sample. The monochromator is readily accessed via an 'insertable coffin'. At present the whole S-A-D assembly is bolted to the reactor floor in one fixed position corresponding to $2\theta_M = 40.5^\circ$, however in the near future it will be mounted on air pads which move on rails around the drum, and $2\theta_M$ will become automatically variable between 30° and 70° . The monochromator will be similarly automated, so that scans with E_i varying can be made.

DIDO Triple-Axis Instrument Details

Angular Ranges	Monochromator take-off angle 40.5° (fixed); Shortly 30-70°. Specimen – analyser angle* -110° to +95° Analyser – detector angle* -95° to +95° M, S, A crystal setting angles $M \pm 160^\circ$; S & A $\pm 320^\circ$. (NB. θ_M , $2\theta_M$ will be computerised in near future). *Limited slightly in certain configurations by the position of the beryllium filter. Mechanical and software limits may be used to define angular range used.
Collimation	In-pile – open Monochromator – sample – 0.33°, 0.75°, 1.5°, 3° Sample – analyser – 0.34°, 0.5°, 0.76°, 1.0° Analyser – detector – 1.0°
Max. Beam Size	40 mm wide × 50 mm high.
Detector	He ³ end window.
Monitor	Low efficiency fission chamber; 20 μgm U ²³⁵ cm ⁻² 10 cm diameter.
Monochromators	(R = reflection, T = transmission) Pyrolytic Graphite (002)R, (004)R etc. (0.4 or 0.8° mosaic) Aluminium planes \perp to $[1\bar{1}0]$ T. Copper (111)R. Other crystals are available 'on loan' if required.
Analysers	Pyrolytic Graphite (002)R, (004)R etc. Germanium planes \perp to $[1\bar{1}0]$ T. Copper (111)R. Other crystals are available 'on loan' if required.
Filters	Pyrolytic Graphite (2" × 2" × 2"), 3.5° ± 1.5° mosaic.
Absorbers/Masks	Polythene absorbers – a variety of thicknesses. Cadmium masks – variety to define beam size.
Flux at Specimen or Monitor	2×10^6 n cm ⁻² s ⁻¹ at 1.6 Å Al (111)T.

Background	4-6 cts/min. during scans from weak incoherently scattering samples [actively being reduced to (we hope) < 1 ct/min].
Range of λ, Q, ω	Present incident wavelength $\lambda_i = 2.32 \text{ \AA}$ (PG002); = 1.62 \AA Al(111), 1.40 \AA Al(002), 0.99 \AA Al(220); and 0.84 \AA Al(113). From fixed $2\theta_M = 40.5^\circ$. Future $\lambda_i = 0.8 \text{ \AA} \rightarrow 3.8 \text{ \AA}$ Momentum transfer 0.5 \AA^{-1} to 12 \AA^{-1} Energy transfer up to ~ 60 meV (neutron energy loss) Energy resolution typically $\sim 5\%$.
Specimen Height	10" or 7½" from table.
Motors	Printed circuit D.C. motors (simultaneous positioning).
Digitisers	Moore-Reid contact type.
Control System	PDP8A CAMAC Interface.
Software Programs	Real space or reciprocal space scan input parameters. Scan mode: linear step scan: up to 64 points per scan up to 84 scans. Input: DECwriter or teletype keyboard, or paper tape, or buffered on FLOPPY DISC. User Programs: LINK, DAIS, DAID, SIRS, LIM, LINT, PRIN, MANU. [It is hoped to add automatic temperature control in the near future].
Data Output	DECwriter or FLOPPY DISC Harwell 6000 Series Units for visual display.
Ancillary Equipment	Variable temperature cryostats 4.5 K - 293 K. Furnace 293 K to 1300 K.

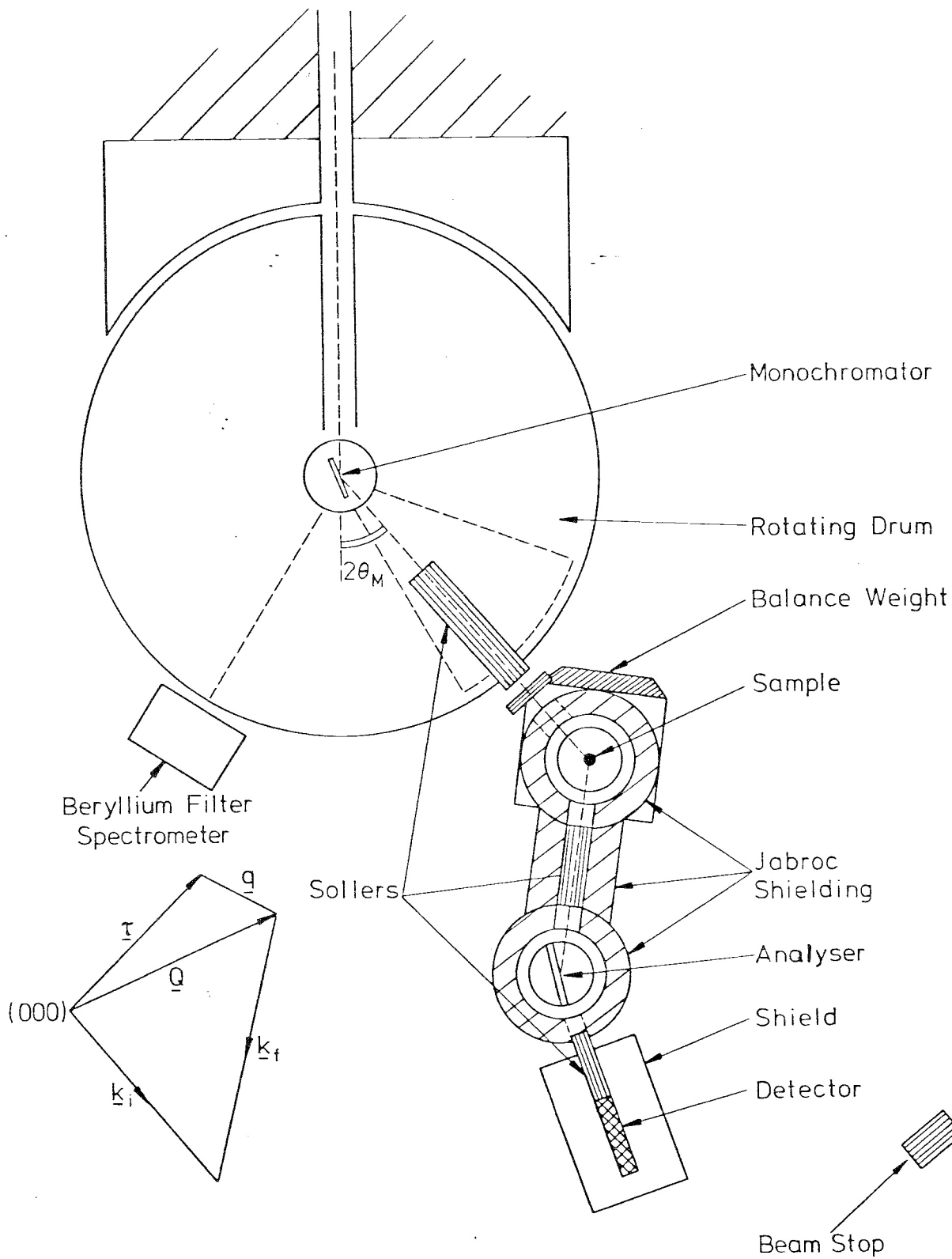

AERE - R.9278 Fig. 8
 Schematic drawing of DIDO triple axis (10H facility)

PLUTO Triple-Axis Spectrometer

Uses

Scans of $\hbar\omega$ may be made by varying either E_i or E_f . The resolution and energy range can be altered quickly by changing the monochromator or analyser from a wide variety of available crystals, by changing the particular plane of the crystal used, or by changing the soller collimators. The parameters which can be changed automatically by the software programs include monochromator or analyser planes from an aligned crystal.

A beryllium filter detector can replace the crystal analyser and detector to give response only to scattered neutrons with energies less than ~ 4.9 meV.

Description

The incident energy is continuously variable by automatic variation of the take-off angle from the monochromator, the shielding drum rotating around the monochromator with sectors being automatically raised to allow passage of the beam from the reactor. The monochromator may be changed in approximately 1½ hours, including alignment, by access via the shielding sectors. The detector is surrounded by a 24" diameter shield which is raised from a large steel base floor by three air pads during movement of the machine. A system of boral shielding rings surrounds the sample and analyser table to reduce background. The soller slit assemblies locate on fixed keyways for quick interchange. The instrument is controlled from a sound-proof air-conditioned room.

For further information see:

M.J. Cooper, J.W. Hall and M.T. Hutchings, *J. Appl. Cryst.* 9, 444 (1976).

J.M. Milne, AERE - R 8309 (1978).

PLUTO Triple-Axis Instrument Details

Angular Ranges (All computerised)

Monochromator take-off angle	20° to 113°
Specimen – analyser angle	-109° to +109°
Analyser – detector angle	-95° to +95°
M, S, A crystal setting angles	-320° to +320°

Mechanical and software limits may be used to define range used.

Collimation

In-pile	0.8° or 1.7°
Monochromator – sample	0.22°, 0.33°, 0.5°, 1° and 2° (standard)
Sample – analyser	0.33°, 0.67°, 1° and 2° (standard); 0.5°, 0.67° and 0.83° (short)
Analyser – detector	0.33°, 0.67°, 1° and 2°.

NB. The sollers in the last three positions may be arranged to define vertical collimation.

Max. Beam Size 50 mm × 50 mm

Detector 2" diameter end window BF₃, or He³, counter
[A cooled beryllium filter detector subtending 16.5° at the specimen is also available, replacing the analyser system].

Monitor Low efficiency fission chamber.

Monochromators (R = reflection, T = transmission)

Aluminium:–	planes \perp [1 $\bar{1}$ 0]T.
Germanium:–	planes \perp [1 $\bar{1}$ 0]T.
Pyrolytic Graphite:–	(002)R, (004)R etc. 0.4° or 0.8° mosaic (Curving about a horizontal axis will be available shortly)
Copper:–	(111)R, (220)T
Beryllium:–	(002)R, (110)T

Analysers As above plus

Zinc:– (002)R, (110)T

Filters 2" × 2" × 2" Graphite, mosaic 3.5 ± 1.5° (before or after sample).

[It is hoped to provide a cooled beryllium filter for use after the sample in the near future].

NB. Use after sample necessitates use of short soller.

Absorbers/Masks	Polythene absorbers $\frac{1}{8}$ " to 2" thick. Cadmium masks $\frac{1}{2}$ " to 1 $\frac{1}{2}$ ", horizontal and vertical aperture.
Flux at Monitor	4×10^6 n cm ⁻² s ⁻¹ from Aluminium (111), $\lambda = 1.2 \text{ \AA}$ 1.4×10^7 n cm ⁻² s ⁻¹ from Pyrolytic Graphite (002), $\lambda = 1.2 \text{ \AA}$
Background	0.3 - 1.5 cts/min. during a typical scan from a low incoherently scattering sample.
Range of λ, Q, ω	Incident wavelength:— 0.8 to 5 \AA Momentum transfer:— 0.5 to 12 \AA^{-1} Energy transfer up to ~ 90 meV extreme limit, ~ 60 meV usual limit (neutron energy loss) Energy resolution typically $\sim 5\%$.
Specimen Height	10" or 7 $\frac{7}{16}$ " above tables 150 kg maximum load a table.
Motors	(Simultaneous positioning) Ironless armature D.C. motor.
Digitisers	Moore-Reid contact type driven by anti-backlash gearing from the shaft.
Control System	Computer controlled or manual operation. PDP8 [To be replaced shortly by a PDP8A] CAMAC interface
Software Programs	Real space or reciprocal space scan input parameters. Scan mode:— linear step scan: up to 64 points per scan, up to 84 scans. Input:— DECwriter or teletype keyboard, or paper tape, or buffered on DECTape. User Programs:— LINK, DAIS, DAID, SIRS, BEFS, LIM, LINT, PRIN, MANU. [It is hoped to add automatic temperature control in the near future].
Data Output	DECwriter and DECTape. Automatic time, temperature print out. Harwell 6000 Series units for visual display.
Ancillary Equipment	Variable temperature cryostat: 4.5 K to 293 K. Furnace 293 K to 1300 K. Superconducting magnets to 6.0 Tesla.

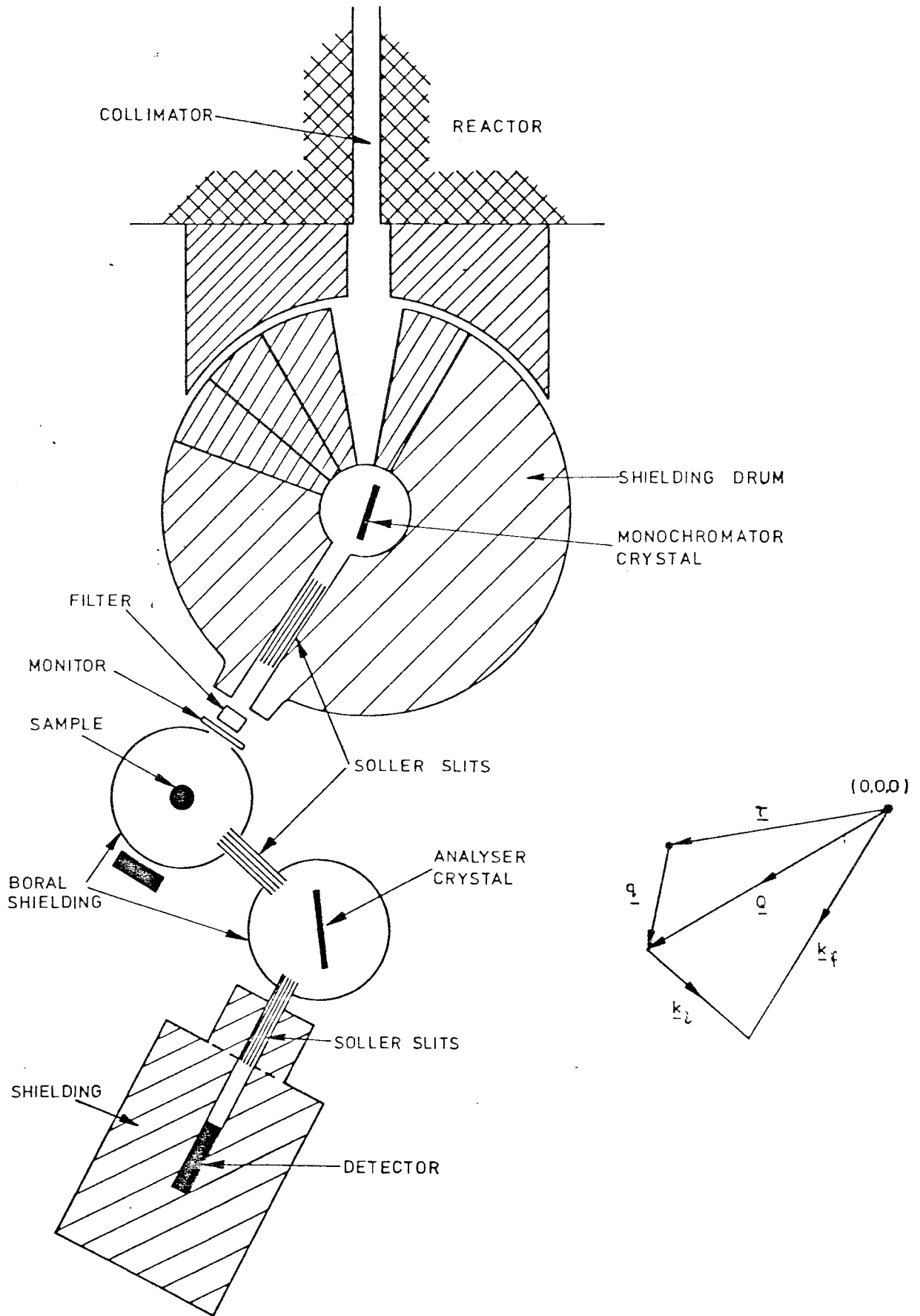

AERE - R.9278 Fig. 9
 Schematic layout of PLUTO triple axis spectrometer

Time of Flight Cold Neutron Twin Rotor Spectrometer

This instrument is a time of flight spectrometer with its own cold source. It uses a pair of multi-slotted rotors to obtain incident energy selection and monochromation. It is used for scattering law measurements over the range 0 to 1000 cm^{-1} with typical values for the energy transfer resolution $\Delta E/E$ of 10%. Its major advantage is its very fast rate of data collection which is made use of in the measurements of densities of states and the study of quasielastic scattering.

The primary spectrometer consists of a pair of rotors turning about vertical axes, and depending upon the particular resolution and intensity considerations of any experiment, rotors with either six or twelve slots may be used. Incident neutron wavelengths between 4 and 12 \AA may be selected by altering the rotor speeds.

The secondary spectrometer consists of a three position sample changing chamber, within which samples may be either heated or cooled, and a detector bank. The sixty-four detector pairs which are in the process of being converted from a BF_3 to a ^3He type, are fixed at a range of scattering angles between 13° and 90° .

The data collection and sample changing is controlled by a dedicated PDP-8 which is being replaced by a PDP-11 V03 system. It is planned that this will have more sophisticated facilities in the future through access to a shared processor. The total count rate from the instrument is ~ 184 counts/sec for a 5% scatterer using 2×6 slot rotors at the maximum flux.

For further information see:

M.B.H. Harryman and J.B. Hayter, USS/P23 (1972).

A.H. Baston, AERE - M 2570 (1972).

R.E. Ghosh, USS/P19 (Rev.) (1974).

Cold Neutron Twin Rotor Spectrometer Instrument Details

Maximum flux at specimen	$1 \times 10^4 \text{ n cm}^{-2} \text{ s}^{-1}$
Beam size at specimen	2.5 cm high \times 5.0 cm wide
Incident wavelength range	4 \rightarrow 12 \AA
Incident energy resolution	$\Delta E_0 = 600 - 1000 \text{ } \mu\text{eV}$
Transfer energy resolution	$20\% > \frac{\Delta E}{E} > 5\%$
Maximum elastic momentum transfer	2.2 \AA^{-1}
Scattering angles	13 angles between 13° and 90°
Detectors	2.5 cm dia., 4 At ^3He detectors
Scattered flight paths	1.1 to 1.9 m depending upon angle
Background	New counters have just been installed and the background is being progressively reduced
Ancillary equipment	Liquid nitrogen and helium cryostats Liquid helium cold finger Furnaces

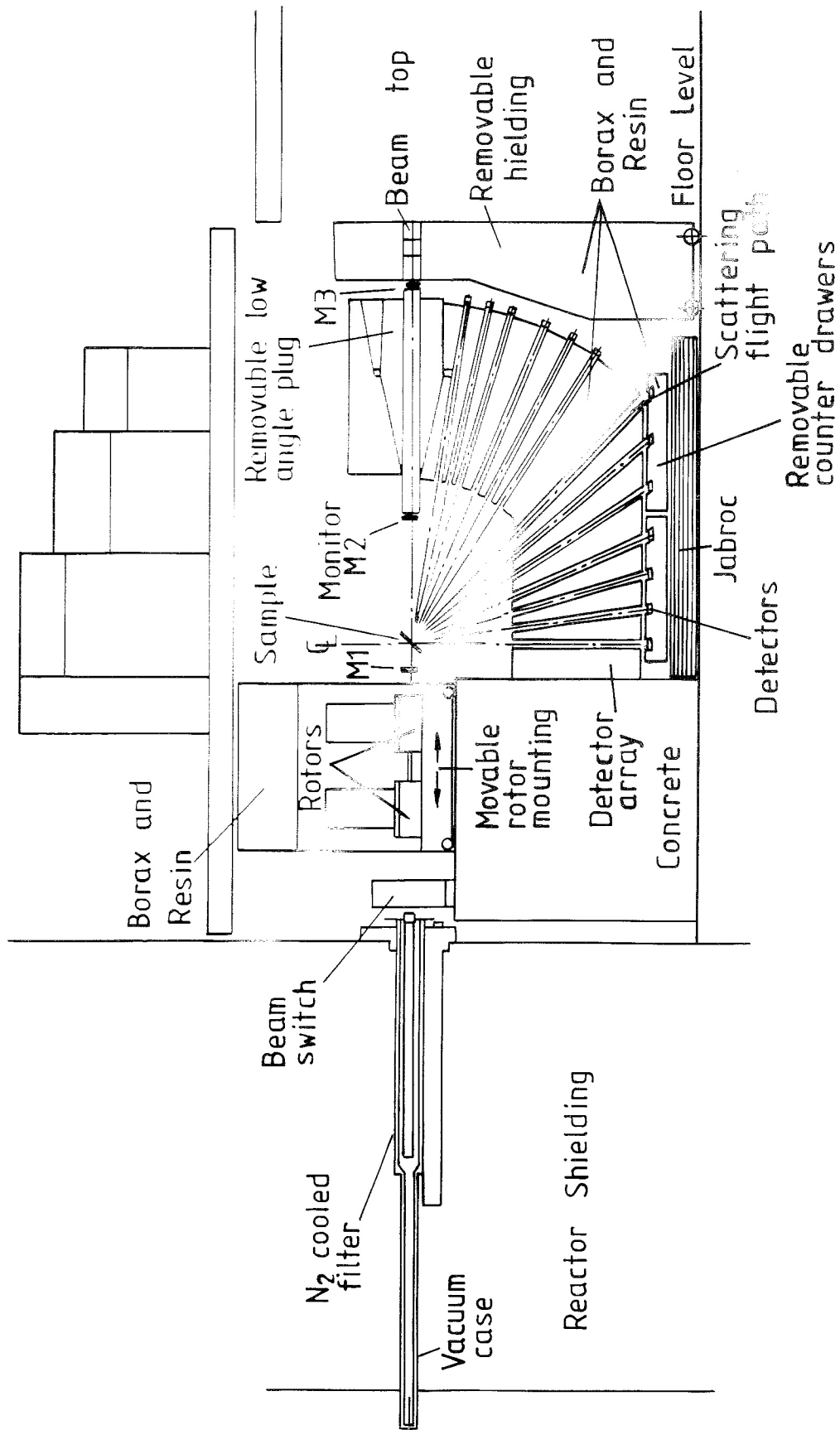

AERE - R.9278 Fig. 10
 Cold neutron spectrometer expt 4H5 DIDO